



AKRAPOVIC RACING & EVOLUTION EXHAUST SYSTEM

for the Kawasaki Ninja ZX-6R Kawasaki 636 Ninja ZX-6R

Congratulations on purchasing an Akrapovic exhaust system. Please read these installation instructions carefully. If you have any trouble installing the system please contact your authorized dealer!

IMPORTANT INFORMATION

Exclusion of Certain Liability

1. The manufacturer, importer or dealer shall not be liable for any incidental damage including personal injury or any other damages caused by improper installation or operation of the Akrapovic exhaust system. When installing the Akrapovic exhaust system be careful that the exhaust system does not touch other parts sensitive to high temperature.
2. Akrapovic makes no representation or warranties with regard to damage caused by the improper installation, use and maintenance of the Akrapovic exhaust system. The warranty is limited to defects recognized by our technical department and to normal use, and excludes items subject to normal wear (gaskets and damping wool). The guarantee is void in case of accident, modification, improper or competition use.
3. Do not attempt to install the Akrapovic exhaust system on a motorcycle for which it was not made or tested by Akrapovic.
4. When the exhaust system gets very hot during operation, be careful not to burn yourself on the exhaust system or parts which are in direct contact with it, even when the motor is not running. Also protect other people, especially children, from the injuries mentioned above.
5. In some cases Akrapovic exhaust system kits contain chemical products (ceramic anti-seizing grease; bolt sealant). Handle with care, do not inhale or swallow. Avoid excessive contact with skin, eyes or mucous membranes. Keep out of reach of children.
6. Technical specifications of Akrapovic exhaust systems and related products subject to change without notice.

Trademarks

The Akrapovic Exhaust System Technology logo is a registered trademark of Akrapovic d.d.

Akrapovic website

Information about Akrapovic exhaust systems and related products is available on the Akrapovic website at:

<http://www.akrapovic.com/>

Copyright

No part of the Akrapovic exhaust system or its documentation may be reproduced or distributed in any form or by any means without the prior written authorization of the Akrapovic company.

© Akrapovic, d.d. All rights reserved.

Symbols

The following symbols are used throughout these installation instructions:



USE BOLT SEALANT; Apply 3 to 4 small drops of bolt sealant onto the cleaned and degreased threads before tightening bolts. **WARNING! Avoid contact with skin, eyes and mucous membranes. Do not inhale fumes. Keep out of the reach of children.**



USE ANTI-SEIZING GREASE (white tube); Prevents seizing, corrosion and excessive wear between the titanium components of your exhaust system. **WARNING! Avoid eye contact. Avoid excessive skin contact. Keep out of the reach of children.**



USE ANTI-SEIZE LEAD-FREE COPPER PASTE (black tube); Provides trouble-free and long-lasting protection against seizing, corrosion and rusting of bolts, threaded ends, nuts, joints, etc. Also protects against vibration, wear and impact. **WARNING! Avoid eye contact. Avoid excessive skin contact. Keep out of the reach of children.**

INSTALLATION INSTRUCTIONS

 **BEFORE INSTALLING CHECK SCHEMATIC OF THE EXHAUST SYSTEM!**

! IF ANY ITEMS IN THE AKRAPOVIC EXHAUST SYSTEM PACKAGE ARE MISSING PLEASE CONTACT YOUR AUTHORIZED DEALER. KEEP THE SCHEMATIC FOR FUTURE REFERENCE.

! THESE INSTALLATION INSTRUCTIONS MUST BE READ CAREFULLY IN ORDER TO ENSURE PROPER INSTALLATION AND OPERATION OF THE AKRAPOVIC EXHAUST SYSTEM.

! THE EXHAUST SYSTEM CAN BE EXTREMELY HOT. ALLOW THE MOTORCYCLE TO COOL DOWN BEFORE BEGINNING INSTALLATION.

 **WE ADVISE YOU TO LEAVE INSTALLATION TO A QUALIFIED SERVICEMAN. IMPROPER INSTALLATION MAY RESULT IN A SHORTER LIFETIME OF THE EXHAUST SYSTEM AND/OR DAMAGE TO THE MOTORCYCLE.**



T-handle 10mm wrench
T-handle swiveling 10mm wrench
T-handle swiveling 12mm wrench
T-handle 4mm three hexagon key wrench
T-handle 5mm three hexagon key wrench
T-handle 6mm three hexagon key wrench
Combination 8mm wrench 2x
Combination 17mm wrench
Spring puller

REMOVAL OF STOCK EXHAUST SYSTEM:

1. Put the motorcycle on a side stand, we recommend a racing stand. Make sure, that surface is solid and flat.
2. Unscrew and remove fuel tank side panels and the rider's seat (**Figure 1, 2, 3, 4**).



Figure 1



Figure 2



Figure 3



Figure 4

- Slide the rubber protection of the cable adjusters, loosen the nuts and shorten the adjusters (**Figure 5**). Remove the safety pin and cables from the exhaust valve servo motor (**Figure 6, 7**). **WARNING: do not remove or disconnect the servo motor!**



Figure 5



Figure 6



Figure 7

- Unscrew the bolt from the metal clamp at the muffler - catalytic converter box joint and muffler hanging bracket. Remove the muffler together with exhaust valve cables (**Figure 8, 9, 10**). **WARNING: be careful not to damage the cables or any other part of the motorcycle during removal!**



Figure 8



Figure 9



Figure 10

5. Unscrew and remove the stock heat shield (Figure 11, 12, 13, 14). Unscrew and remove the bolt from the catalytic converter box bracket (Figure 15).



Figure 11



Figure 12



Figure 13



Figure 14



Figure 15

6. Unscrew and remove the lower part of the cowling (Figure 16, 17, 18, 19, 20, 21).



Figure 16



Figure 17

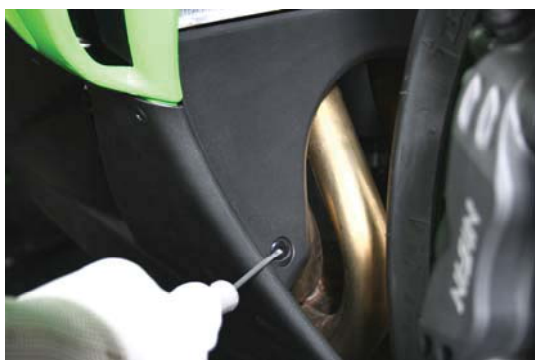

Figure 18



Figure 19



Figure 20

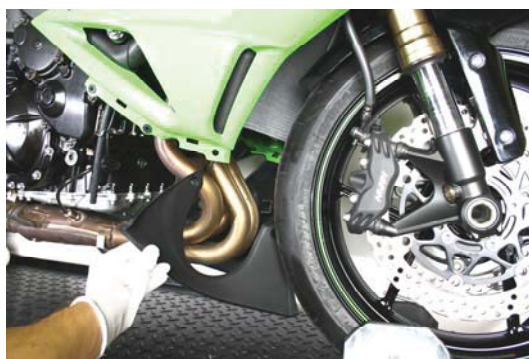

Figure 21

7. Unscrew the lambda sensor (Figure 22).



Figure 22

8. Unscrew the nuts from the header tube flanges and remove them together with catalytic converter box (Figure 23, 24). **WARNING: make sure not to damage the cooling fins of the water cooler or any other part of the motorcycle!**



Figure 23

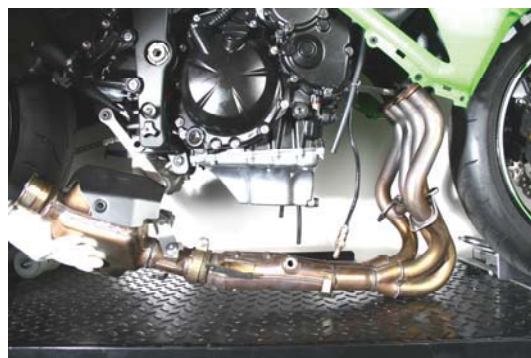

Figure 24

INSTALLATION OF THE AKRAPOVIČ RACING OR EVOLUTION EXHAUST SYSTEM:

1. Set up the sleeves together with the stock gaskets, flanges and springs; make sure they are correctly oriented (Figure 25, 26). Hand tighten the flanges. **WARNING: make sure not to damage the cooling fins of the water cooler or any other part of the motorcycle during this process!**



Figure 25



Figure 26

2. For easier mounting put headers and collectors together correctly and attach the springs (Figure 27, 28). **WARNING: make sure, that springs pull the collectors all the way onto the headers – use rubber mallet if necessary to tap the connections into place!** Make sure that collectors are correctly oriented. **For Evolution exhaust only:** coat the interior side of the input bushes of the titanium collectors with Akrapovic ceramic anti-seizing grease (white tube).



Figure 27



Figure 28

3. Insert the header tubes and attach the springs (Figure 29). **WARNING: make sure, that springs pull the headers all the way into the sleeves – use rubber mallet if necessary to tap the connections into place!** Tighten the flanges (Figure 30). **WARNING: make sure not to damage the cooling fins of the water cooler or any other part of the motorcycle during this process!**



Figure 29

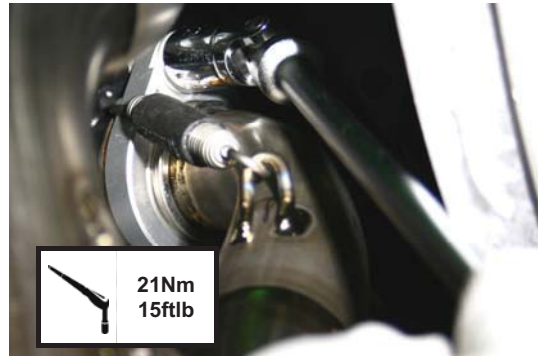

Figure 30

4. Tighten the lambda sensor (Figure 31, 32). **WARNING: grease only the threads of the lambda sensor with Akrapovic anti-seize lead-free copper paste (black tube)!**

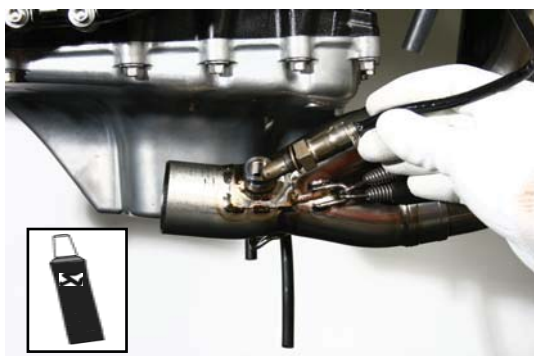

Figure 31

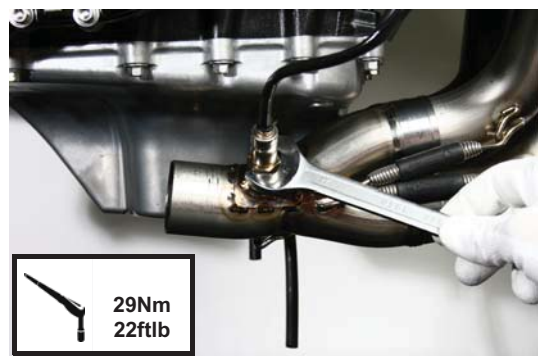

Figure 32

- Slide the link pipe onto the collectors and attach the springs (Figure 33, 34). **Warning: make sure, that springs pull the link pipe all the way onto the collectors – use rubber mallet if necessary to tap the connections into place!** For Evolution exhaust only: coat the interior side of the input bushes of the titanium link pipe with Akrapovic ceramic anti-seizing grease (white tube).

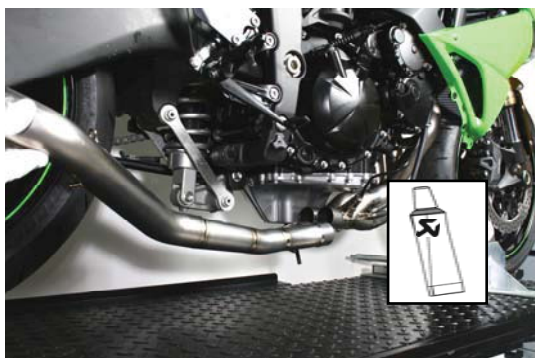

Figure 33



Figure 34

- Correctly position the carbon-fiber clamp and slide it onto the muffler - bear in mind the **left offset** of the carbon-fiber clamp viewed from the rear. **WARNING: open the clamp slightly wider than the diameter of the outer sleeve of the muffler – do not scrape it along the muffler outer sleeve!** (Figure 35).



Figure 35

- Position the muffler correctly, slide it onto the outlet side of the link pipe and attach the springs (Figure 36, 37). For Evolution exhaust only: coat the interior side of the input bushes of the muffler with Akrapovic ceramic anti-seizing grease (white tube). **WARNING: make sure, that springs pull the muffler all the way onto the link pipe – use rubber mallet if necessary to tap the connection into place!**



Figure 36



Figure 37

8. Align the muffler in respect to the motorcycle and tighten the muffler clamp using Akrapovic bolt, washer and nut as shown in figures (Figure 38, 39, 40, 41). Make sure that muffler is centered with respect to the motorcycle and that the link pipe or muffler are not touching the frame or any other part of the motorcycle.



Figure 38



Figure 39



Figure 40



Figure 41

9. **For CONICAL SHAPE MUFFLER only:** Position the muffler correctly, slide it onto the outlet side of the link pipe and attach the springs (Figure 42, 43). **For Evolution exhaust only:** coat the interior side of the input bushes of the muffler with Akrapovic ceramic anti-seizing grease (white tube). **WARNING!** make sure, that springs pull the muffler all the way onto the link pipe – use rubber mallet if necessary to tap the connections into place!



Figure 42



Figure 43

10. For **CONICAL SHAPE MUFFLER only**: align the muffler in respect to the motorcycle and tighten the muffler bracket onto the stock chassis hanging bracket using the stock bolt, washer and nut (**Figure 44, 45, 46**). Make sure that the muffler is centered with respect to the motorcycle before you tighten the muffler bracket. Make sure that the link pipe or muffler are not touching the frame or any other parts of the motorcycle.



Figure 44



Figure 45



Figure 46

11. Reinstall the lower part of the cowling (**Figure 47, 48**).



Figure 47

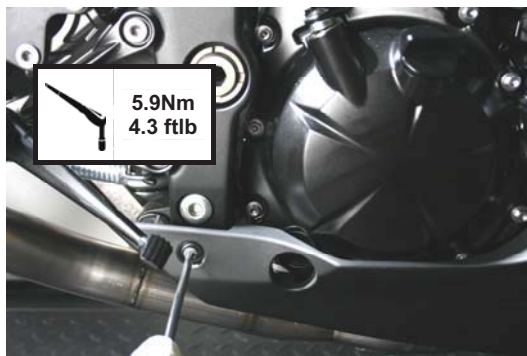

Figure 48

Final installation:

1. Clean grease spots:
 - a. Muffler – carbon-fiber outer sleeve: use a soft dry cloth.
 - b. Muffler – titanium outer sleeve: use a soft cloth sprayed with a multi-purpose spray lubricant (WD-40 or equivalent).
 - c. Muffler – carbon-fiber outlet cap: use a soft dry cloth.
 - d. RACING - stainless steel link pipe, collectors and header tubes: use a soft cloth sprayed with a contact cleaner, then wipe with a soft dry cloth
 - e. EVOLUTION - titanium link pipe, collectors and header tubes: use a soft cloth sprayed with a multi-purpose spray lubricant (WD-40 or equivalent).

Cleaning will prevent spots from burning onto the surface. Do not use aggressive chemical cleaners, because they can damage the sticker.

2. Check the operation of the brakes and suspension. Make sure all the bolts are sufficiently tightened. In case the exhaust system touches the cowling or other parts repeat the adjustment of the exhaust system or contact your authorized dealer.

! IT IS NORMAL IF WHITE SMOKE COMES OUT OF THE MUFFLER ON FIRST OPERATION.

! DO NOT STAND BEHIND THE MUFFLER ON FIRST OPERATION.

! DO NOT USE AUTOMOTIVE WHEEL CLEANERS OR ANY CLEANING PRODUCTS WHICH CONTAIN ACIDIC ADDITIVES TO CLEAN AKRAPOVIC EXHAUST SYSTEMS.

MAINTENANCE OF THE AKRAPOVIC EXHAUST SYSTEM

1. Clean the titanium exhaust components with a multi-purpose spray lubricant (WD-40 or equivalent), carbon fiber exhaust components with soft and dry cloth and stainless steel components with soft cloth sprayed with contact cleaner, then wipe with soft and dry cloth. Do not use aggressive chemical cleaners, because they can damage the sticker. A change in the color of the exhaust system is normal due to the high temperatures.
2. The wearing out of the muffler silencing material depends on the type of the engine and riding style. Contact your dealer/serviceman if visible changes appear on muffler's outer sleeve or the noise level is increased.
3. Periodically make sure all the bolts and springs are sufficiently tight.

WARNING:

Please note that certain aftermarket exhaust systems may not comply with applicable California laws and regulations, and may therefore be prohibited for use on California highways or roads, or on roads or vehicles otherwise subject to emissions control requirements.

Akrapovič exhaust systems for automobiles and motorcycles mounted downstream of the catalytic converter (also known as "cat-back systems") are considered "replacement parts" in California by the California Air Resources Board (CARB), and do not require an exemption or executive order from CARB to be sold in California. However, California prohibits the use of any aftermarket exhaust system that modifies, removes or replaces original equipment catalysts, unless CARB has issued an Executive Order as to such part or system.

Further, Akrapovič parts or exhaust systems used or intended for use on "racing vehicles" (i.e. a competition vehicle used exclusively for competition on closed-course circuits) do not require an exemption or Executive Order from CARB to be sold in California. However, such parts are prohibited from use on California public highways or roads, even if occasionally used "off-road."