

PLO9350N - KL09350N

PORTAVALIGIE LATERALE SPECIFICO - SPECIFIC TUBULAR SIDE-CASE HOLDER - PORTE-VALISES LATÉRAUX SPÉCIFIQUE
 SPEZIFISCHES STAHLROHR-SEITENTRAEGER - PORTA MALETAS LATERALES ESPECÍFICO - SUPORTE DE MALAS ESPECÍFICO

MOTO MORINI X-CAPE 649 (2021)

N°	Descrizione/Description	Caratteristiche/Features	Codice/Code	Quantità/quantity
1	Telaio laterale - Side frame - Châssis latéral Soporte lateral - Seitenrahmen - Suporte lateral	-	PLO9350NDXV PLO9350NSXV	2 (Right: Left)
2	Ponte - Bridge - Pont Brücke - Puente - Ponte	-	GNB2869V	1
3	Supporto Freccie - Indicators support Support clignotants - Blinkerhalterung Soporte para los indicadores - Suporte para indicadores	-	GL5041DXV GL5041SXV	2 (Right: Left)
4	Supporto inferiore - Lower support Support inférieur - Soporte inferior Untere Halterung - Suporte inferior	-	GL5040DXV GL5040SXV	2 (Right: Left)
5	Paracalore - Heat Guard Hitzeschutz - Pare Chaleur Protector De Calor - Protetor De Calor	-	GL5042V	1
6	Vite - Screw - Vis - Schraube Tornillo - Parafuso	TBEI M8x20	820TBEI	2
7	Vite - Screw - Vis - Schraube Tornillo - Parafuso	TBEI M8x50	850TBEI	2
8	Vite - Screw - Vis - Schraube Tornillo - Parafuso	TBEI M8x25	825TBEI	4
9	Vite - Screw - Vis - Schraube Tornillo - Parafuso	TBEI M8x65	865TBEI	2
10	Vite - Screw - Vis - Schraube Tornillo - Parafuso	TBEI M8x75	875TBEI	2
11	Vite - Screw - Vis - Schraube Tornillo - Parafuso	TBEIFN M6x14	614TBEIFN	4
12	Vite - Screw - Vis - Schraube Tornillo - Parafuso	TBEI M10x20	1020TBEI	2
13	Rondella spaccata - Split washer Scheibe - Rondelle fendue Arandela seccionada - Arruela Dentada	Foro Ø8mm	Z1060	6
14	Rondella Inox - Stainless Steel Washer Rondelle Inox - Rostfreie Unterlegscheibe Aus Stahl Arandela Inox - Arruela Lisa De Aço Inox	Foro Ø8mm Esterno Ø14mm Sp.0,3mm	805RONX	2
15	Rondella - Washer - Rondelle - Scheibe Arandela - Arruela	Foro Ø8mm Esterno Ø14mm	814RON	2
16	Rondella - Washer - Rondelle - Scheibe Arandela - Arruela	Foro Ø8mm Esterno Ø20mm Sp.2mm	820RON	14
17	Rondella Inox - Stainless Steel Washer Rondelle Inox - Rostfreie Unterlegscheibe Aus Stahl Arandela Inox - Arruela Lisa De Aço Inox	Foro Ø10mm Sp.1mm	101RON	6
18	Distanziale - Spacer Entretoise - Distanzstueck Distanciador - Espaçador	Ø20x8 Foro 10,5mm	C20L8F10,5T	2
19	Distanziale - Spacer Entretoise - Distanzstueck Distanciador - Espaçador	Ø22x31 Foro 8,5mm	C22L31F8,5ALT	2

PLO9350N - KL09350N

PORTAVALIGIE LATERALE SPECIFICO - SPECIFIC TUBULAR SIDE-CASE HOLDER - PORTE-VALISES LATÉRAUX SPÉCIFIQUE
SPEZIFISCHES STAHLROHR-SEITENTRAEGER - PORTA MALETAS LATERALES ESPECÍFICO - SUPORTE DE MALAS ESPECÍFICO

MOTO MORINI X-CAPE 649 (2021)

N°	Descrizione/Description	Caratteristiche/Features	Codice/Code	Quantità/quantity
20	Dado - Bolt - Ecrou Mutter - Tuerca - Porca	Dado Autobloccante Flangiato M8 (H.9.5mm)	8DADIFN	6
21	Dado - Bolt - Ecrou Mutter - Tuerca - Porca	Dado Autobloccante Flangiato Alto M6 (H.9mm)	6DADIAFLN	4
22	Dado - Bolt - Ecrou Mutter - Tuerca - Porca	Dado Autobloccante M10	10DADIB	2
23	Tappo - Cap - Fiche - Stecker Enchufe - Capa	-	13COP	6
24	Boccola - Mounting bush - Entretoise de montage Cilindro de fijación Montagehülse - Bucha de fixação	-	Z4039	4
25	Componenti Originali - Original Parts Parties Originales - Original Bauteile Componentes Originales - Componentes Originais	-	-	-
26	Particolari Inclusi nel 05RKIT Components Included In The 05RKIT Pièces Inclues Dans 05RKIT Die Einzelnen Teile Sind Bei 05RKIT Despieces Incluidos 05RKIT Componentes incluidos na 05RKIT	-	-	-
27	Particolari Inclusi nel SR9350 Components Included In The SR9350 Pièces Inclues Dans SR9350 Die Einzelnen Teile Sind Bei SR9350 Despieces Incluidos SR9350 Componentes incluidos na SR9350	-	-	-
28	Particolari Inclusi nel OFMK/OFCAM Components Included In The OFMK/OFCAM Pièces Inclues Dans OFMK/OFCAM Die Einzelnen Teile Sind Bei OFMK/OFCAM Despieces Incluidos OFMK/OFCAM Componentes incluidos na OFMK/OFCAM	-	-	-
29	Supporto - Support - Support Halterung - Soporte - Apoio	-	GN1009T	2

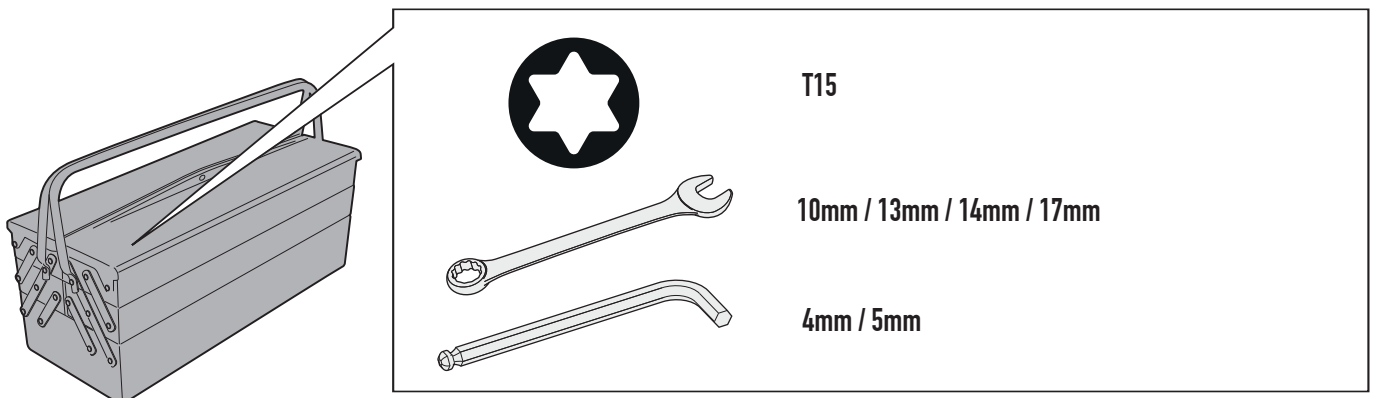

ISTRUZIONI DI MONTAGGIO - MOUNTING INSTRUCTIONS
INSTRUCTIONS DE MONTAGE - BAUANLEITUNG
INSTRUCCIONES DE MONTAJE - INSTRUÇÕES DE MONTAGEM

PLO9350N - KL09350N

PORTAVALIGIE LATERALE SPECIFICO - SPECIFIC TUBULAR SIDE-CASE HOLDER - PORTE-VALISES LATÉRAUX SPÉCIFIQUE
 SPEZIFISCHES STAHLROHR-SEITENTRAEGER - PORTA MALETAS LATERALES ESPECÍFICO - SUPORTE DE MALAS ESPECÍFICO

MOTO MORINI X-CAPE 649 (2021)

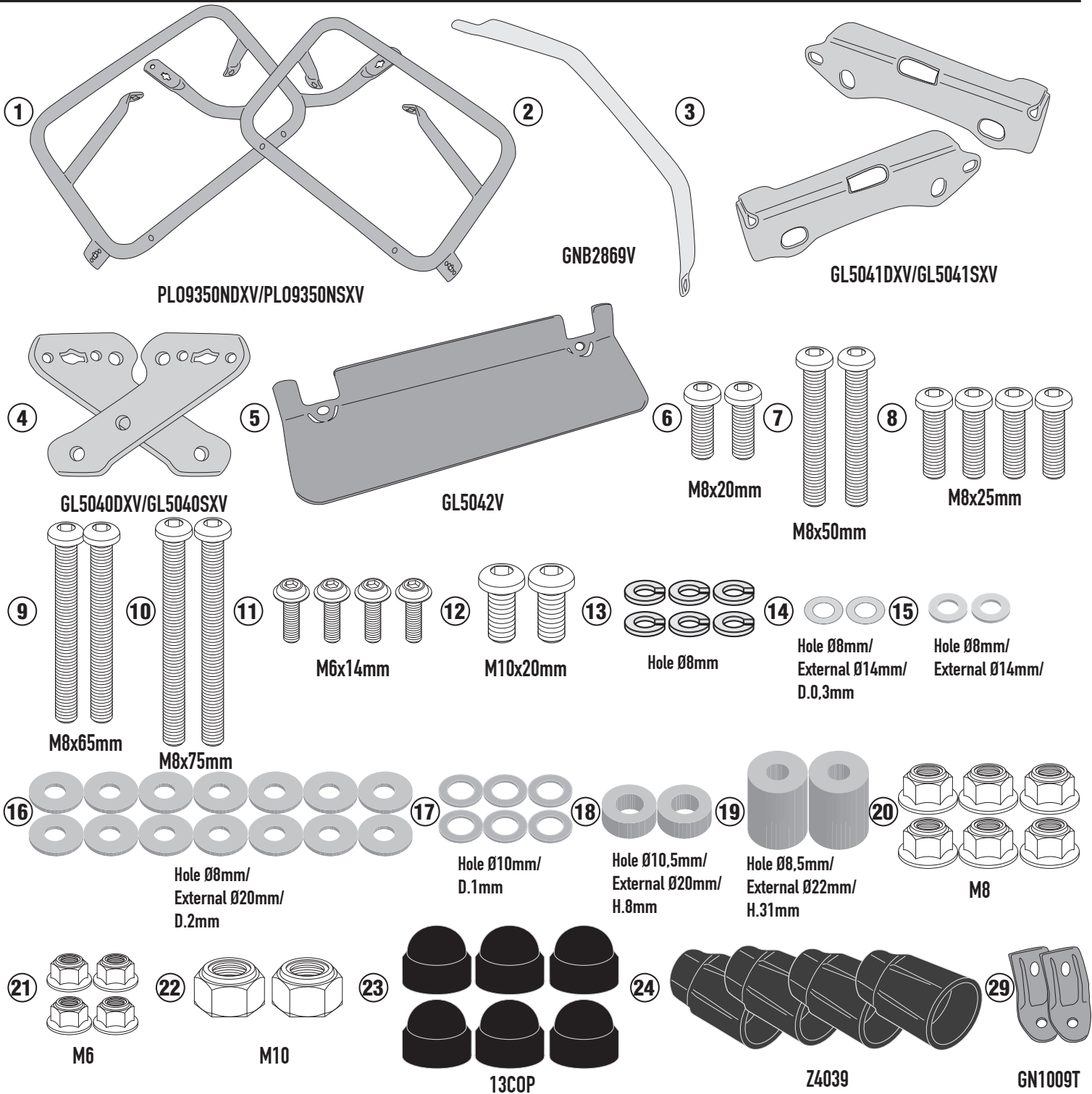

- Da abbinare al kit OFMK per l'utilizzo di valigie Monokey o al kit OFCAM per l'utilizzo di valigie MONOKEY® CAM-SIDE Trekker Outback
 - To be combined with OFMK kit for Monokey cases or OFCAM kit for Trekker Outback MONOKEY® CAM-SIDE
- À combiner avec le kit OFMK pour valises MONOKEY® ou le kit OFCAM pour Trekker Outback MONOKEY® CAM-SIDE
 - Zu montieren mit kit OFMK für MONOKEY® offer oder kit OFCAM für Trekker Outback MONOKEY® CAM-SIDE
- A combinar con el kit OFMK para maletas MONOKEY® o el kit OFCAM para Trekker Outback MONOKEY® CAM-SIDE
 - Para ser combinado com o kit OFMK para malas MONOKEY® ou o kit OFCAM para Trekker Outback MONOKEY® CAM-SIDE

PL09350N - KL09350N

PORTAVALIGIE LATERALE SPECIFICO - SPECIFIC TUBULAR SIDE-CASE HOLDER - PORTE-VALISES LATÉRAUX SPÉCIFIQUE
SPEZIFISCHES STAHLROHR-SEITENTRAEGER - PORTA MALETAS LATERALES ESPECÍFICO - SUPORTE DE MALAS ESPECÍFICO

MOTO MORINI X-CAPE 649 (2021)

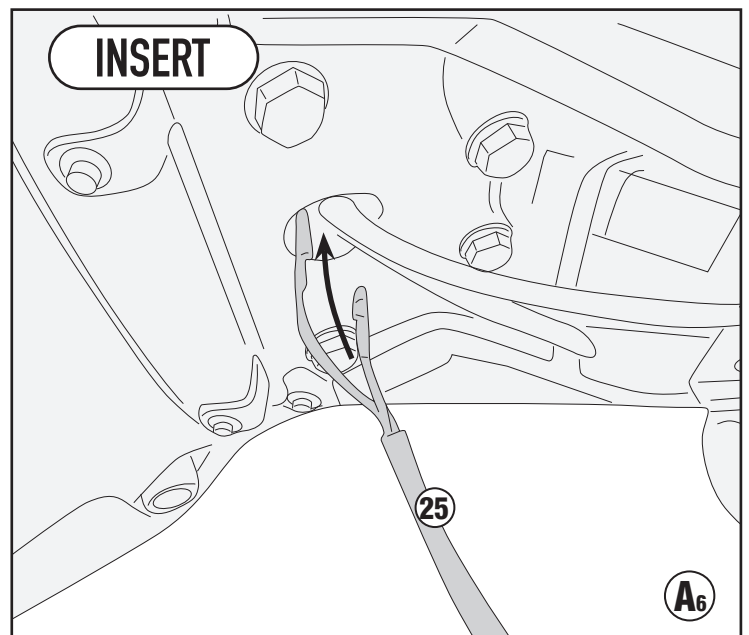
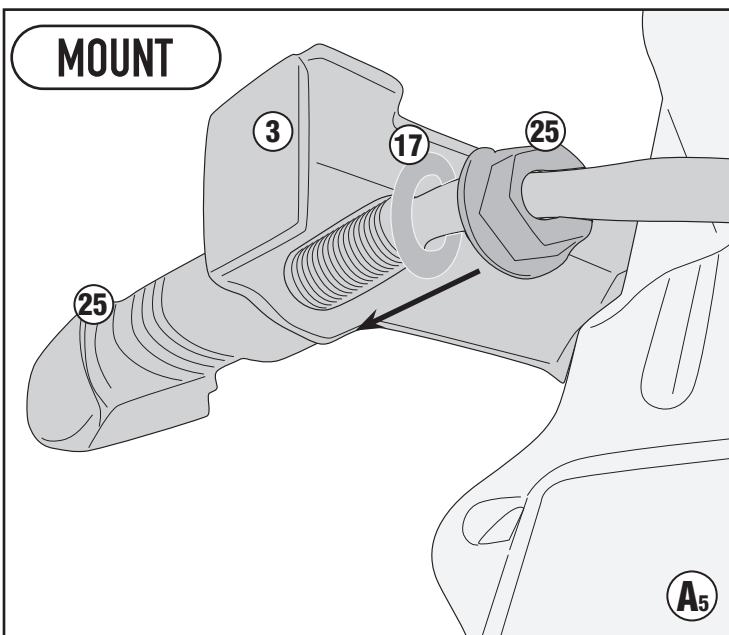
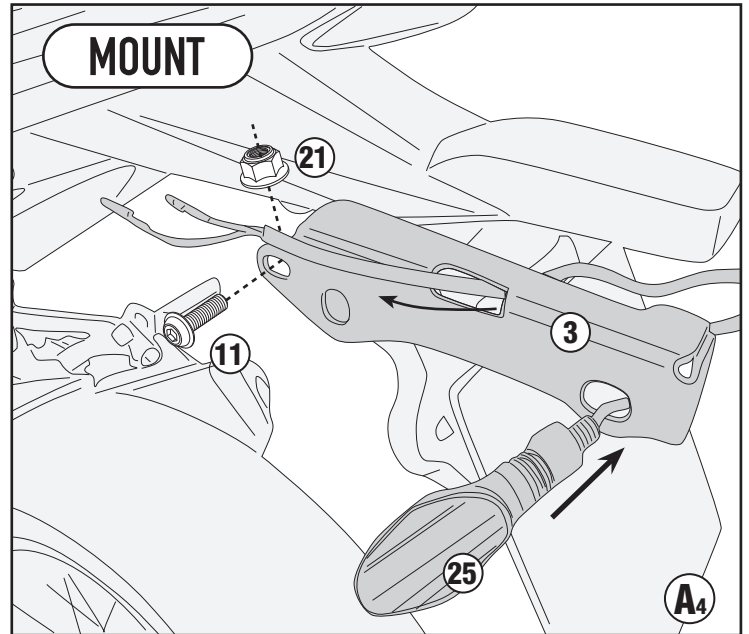
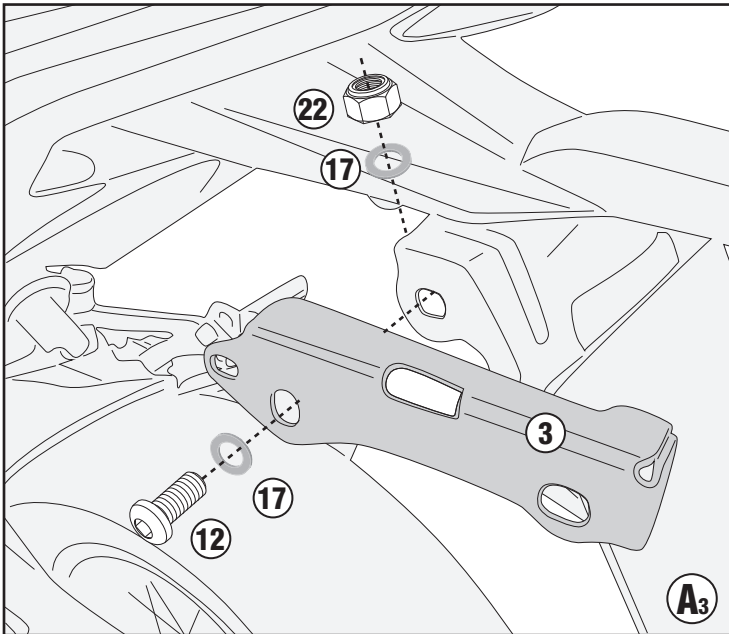
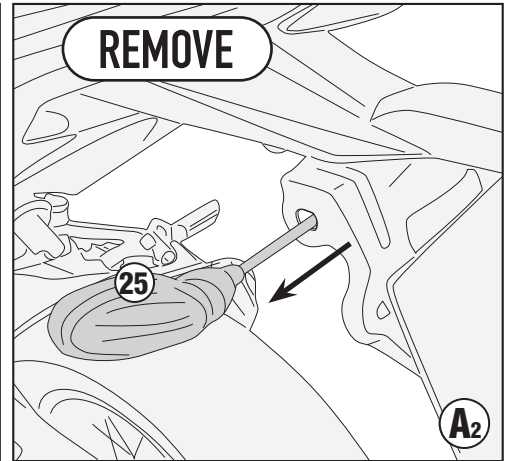
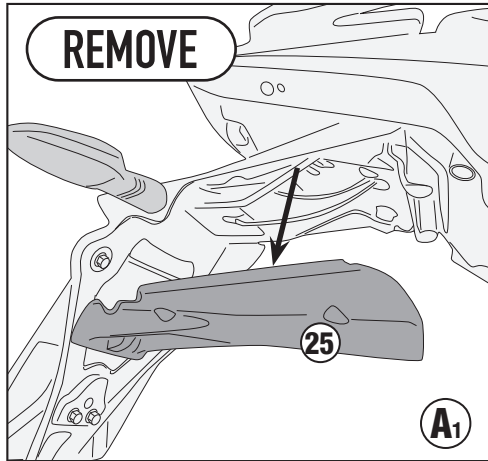
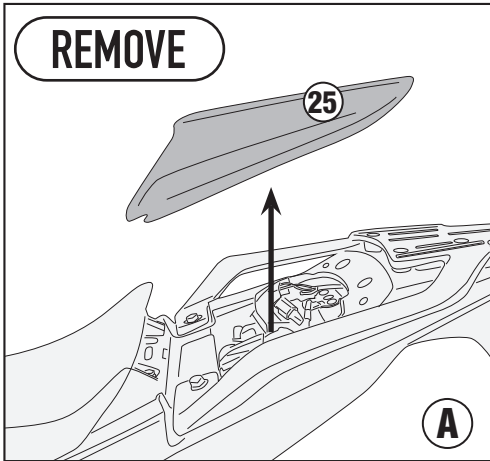

PL09350N - KL09350N

PORTAVALIGIE LATERALE SPECIFICO - SPECIFIC TUBULAR SIDE-CASE HOLDER - PORTE-VALISES LATÉRAUX SPÉCIFIQUE
SPEZIFISCHES STAHLROHR-SEITENTRAEGER - PORTA MALETAS LATERALES ESPECÍFICO - SUPORTE DE MALAS ESPECÍFICO

MOTO MORINI X-CAPE 649 (2021)

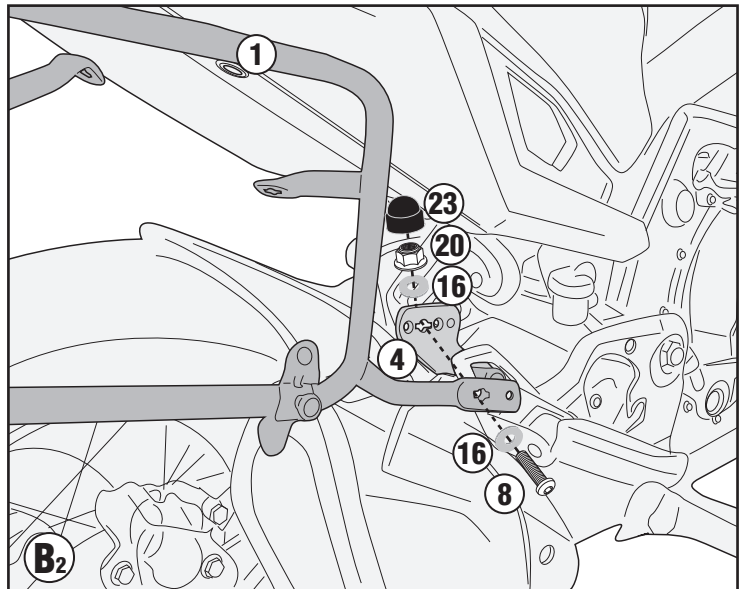
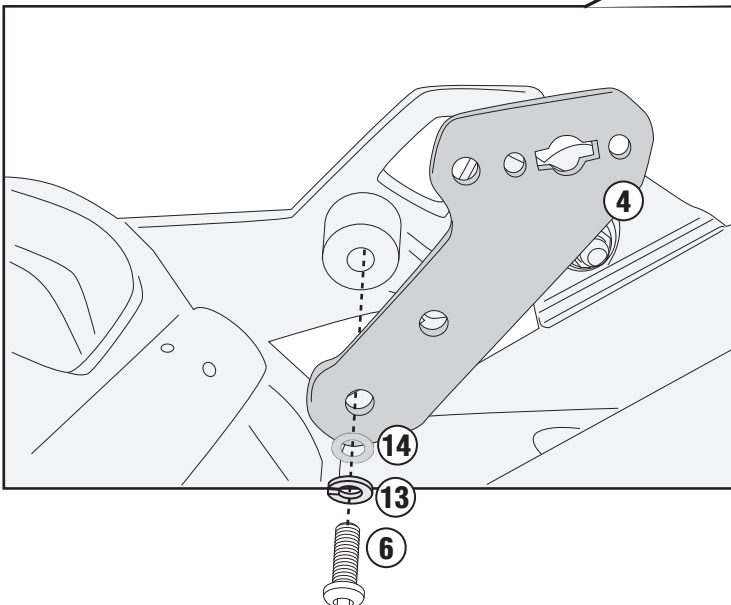
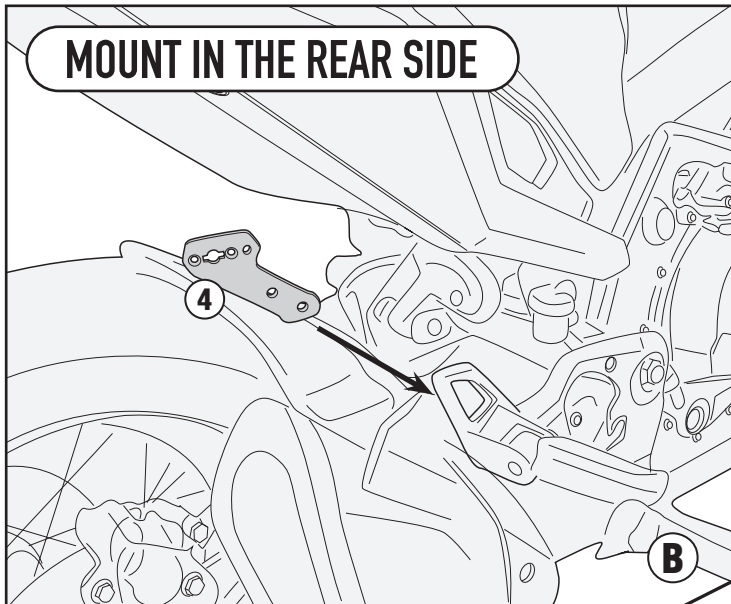
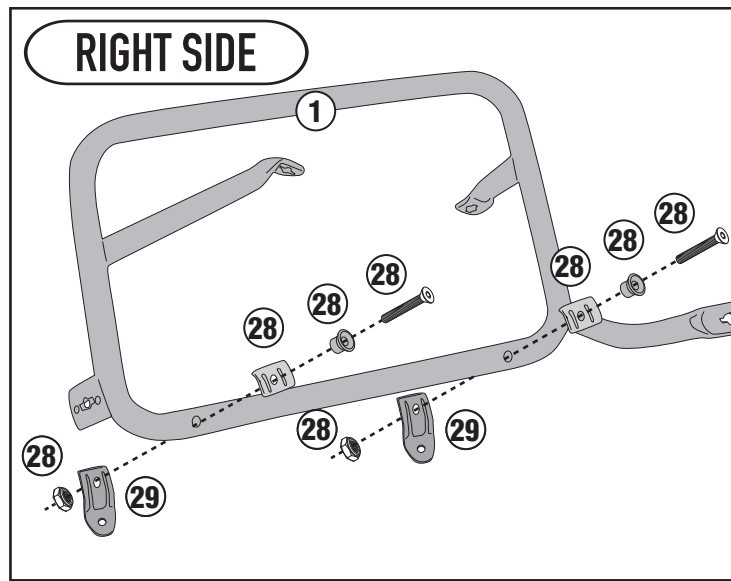

PLO9350N - KL09350N

PORTAVALIGIE LATERALE SPECIFICO - SPECIFIC TUBULAR SIDE-CASE HOLDER - PORTE-VALISES LATÉRAUX SPÉCIFIQUE
SPEZIFISCHES STAHLROHR-SEITENTRAEGER - PORTA MALETAS LATERALES ESPECÍFICO - SUPORTE DE MALAS ESPECÍFICO

MOTO MORINI X-CAPE 649 (2021)

ONLY PLO9350

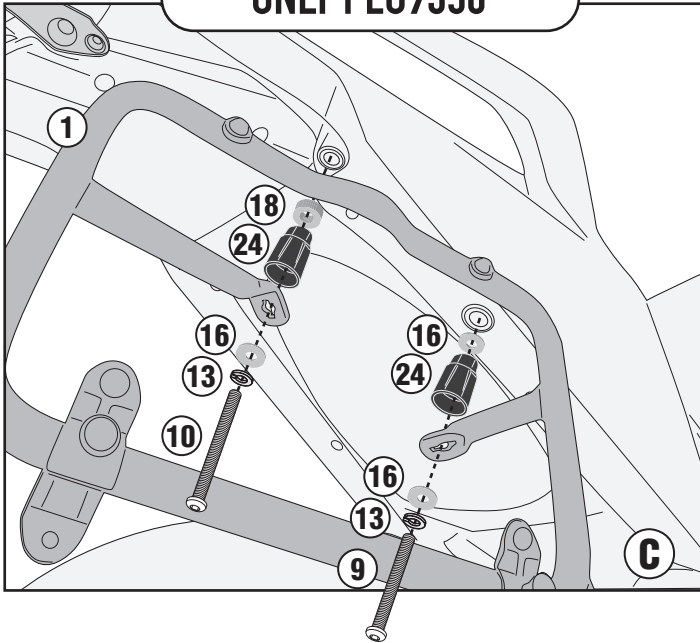

SR9350 + PLO9350

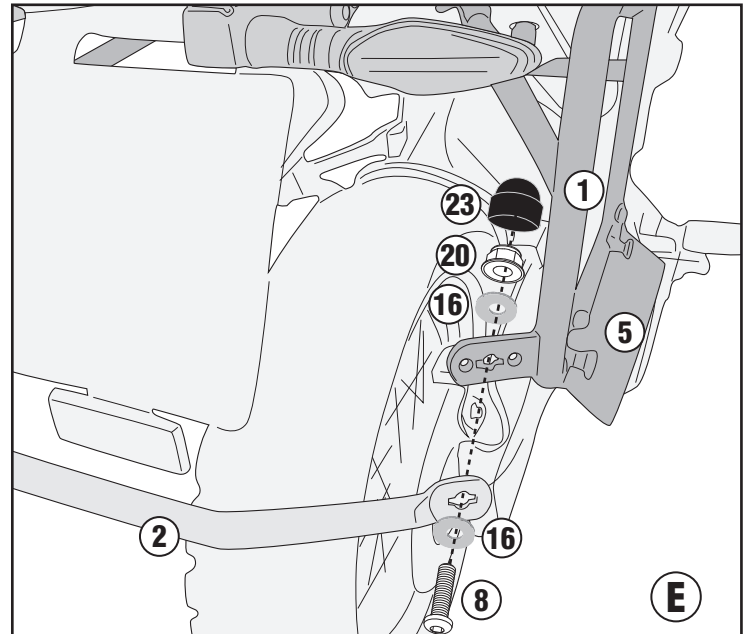
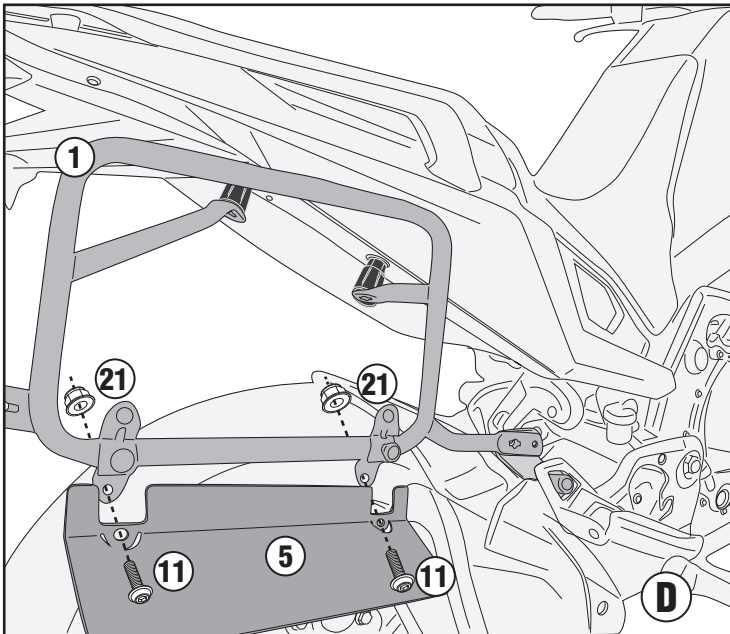
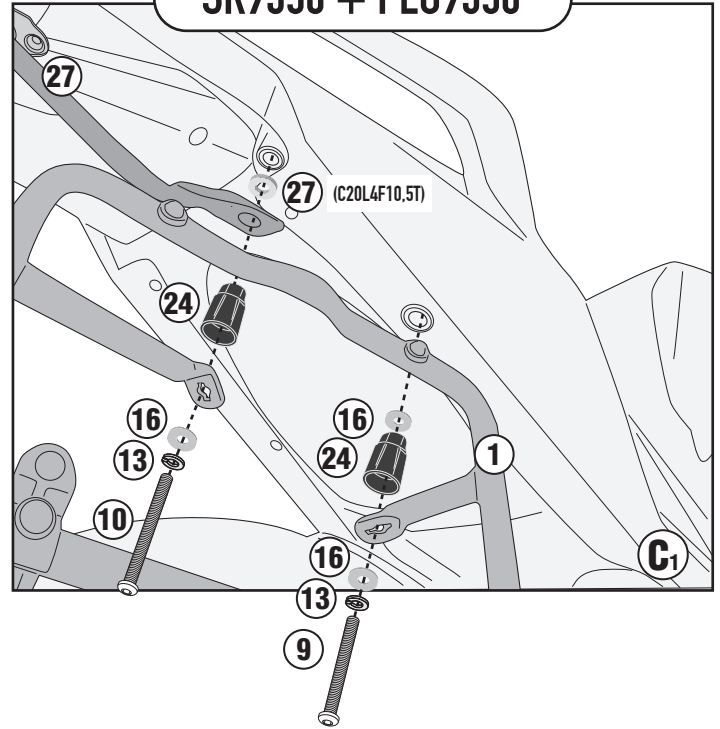

PL09350N - KL09350N

PORTAVALIGIE LATERALE SPECIFICO - SPECIFIC TUBULAR SIDE-CASE HOLDER - PORTE-VALISES LATÉRAUX SPÉCIFIQUE
 SPEZIFISCHES STAHLROHR-SEITENTRÄGER - PORTA MALETAS LATERALES ESPECÍFICO - SUPORTE DE MALAS ESPECÍFICO

MOTO MORINI X-CAPE 649 (2021)

- TRASFORMAZIONE IN PORTAVALIGIE LATERALI RAPID FITTING, AGGIUNDO IL KIT 05RKIT (DA ACQUISTARE SEPARATAMENTE)
- TRANSFORMATION INTO A RAPID FITTING SIDE-CASE HOLDER, BY ADDING THE 05RKIT KIT (TO BE PURCHASED SEPARATELY)
- VERARBEITUNG ZU EINEM SCHNELL MONTIERBAREN SEITENTRÄGER UNTER HINZUFÜGUNG DES 05RKIT-KITS (SEPARAT ZU ERWERBEN)
 - TRANSFORMABLE EN KIT DE FIXATION LATÉRAL RAPIDE, EN AJOUTANT LE KIT 05RKIT (À ACHETER SÉPARÉMENT)
- SE TRANSFORMA EN UN PORTAMALETAS LATERAL DE AJUSTE RÁPIDO, AÑADIENDO EL KIT 05RKIT (SE COMPRA POR SEPARADO)
- CONVERTE EM UM RACK DE PAINEL LATERAL DE ENCAIXE RÁPIDO, ADICIONANDO O KIT 05RKIT (ADQUIRIDO SEPARADAMENTE)

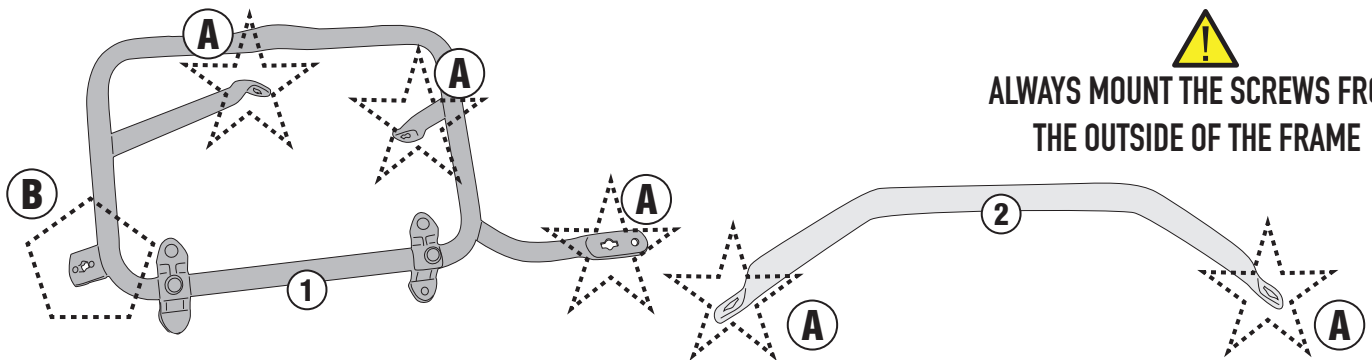

ALWAYS MOUNT THE SCREWS FROM THE OUTSIDE OF THE FRAME



TYPE A

(See the figure above for the correct type)

CORRECT SIDE



INSERT

ATTENTION TO THE CORRECT ASSEMBLY

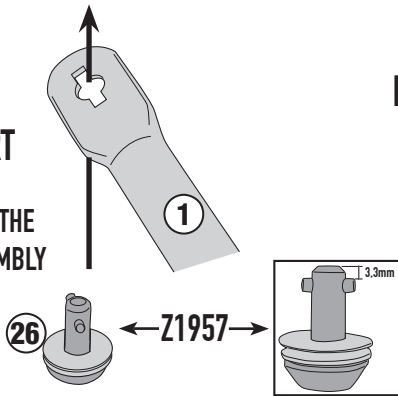

INSERT



ATTENTION TO THE CORRECT ASSEMBLY

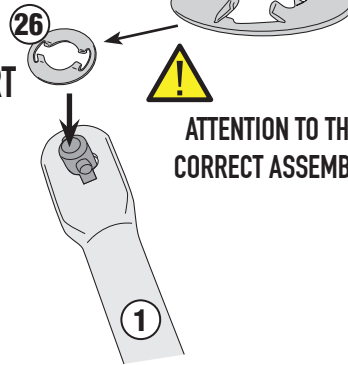

TYPE B

(See the figure above for the correct type)

LATO SVASATO
FLARING SIDE

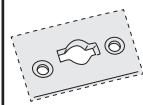

(M4 X 12 TSPX)

(M4 X 12 TSPX)

REAR SIDE
LATO PIATTO
FLAT SIDE

MOUNT IN THE REAR SIDE



ATTENTION TO THE CORRECT ASSEMBLY

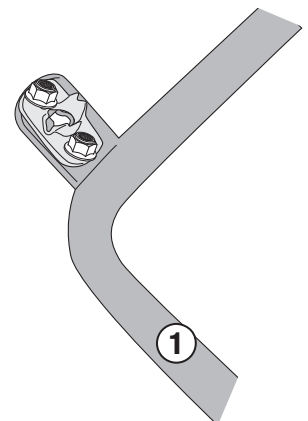

PL09350N - KL09350N

PORTAVALIGIE LATERALE SPECIFICO - SPECIFIC TUBULAR SIDE-CASE HOLDER - PORTE-VALISES LATÉRAUX SPÉCIFIQUE
SPEZIFISCHES STAHLROHR-SEITENTRAEGER - PORTA MALETAS LATERALES ESPECÍFICO - SUPORTE DE MALAS ESPECÍFICO

MOTO MORINI X-CAPE 649 (2021)

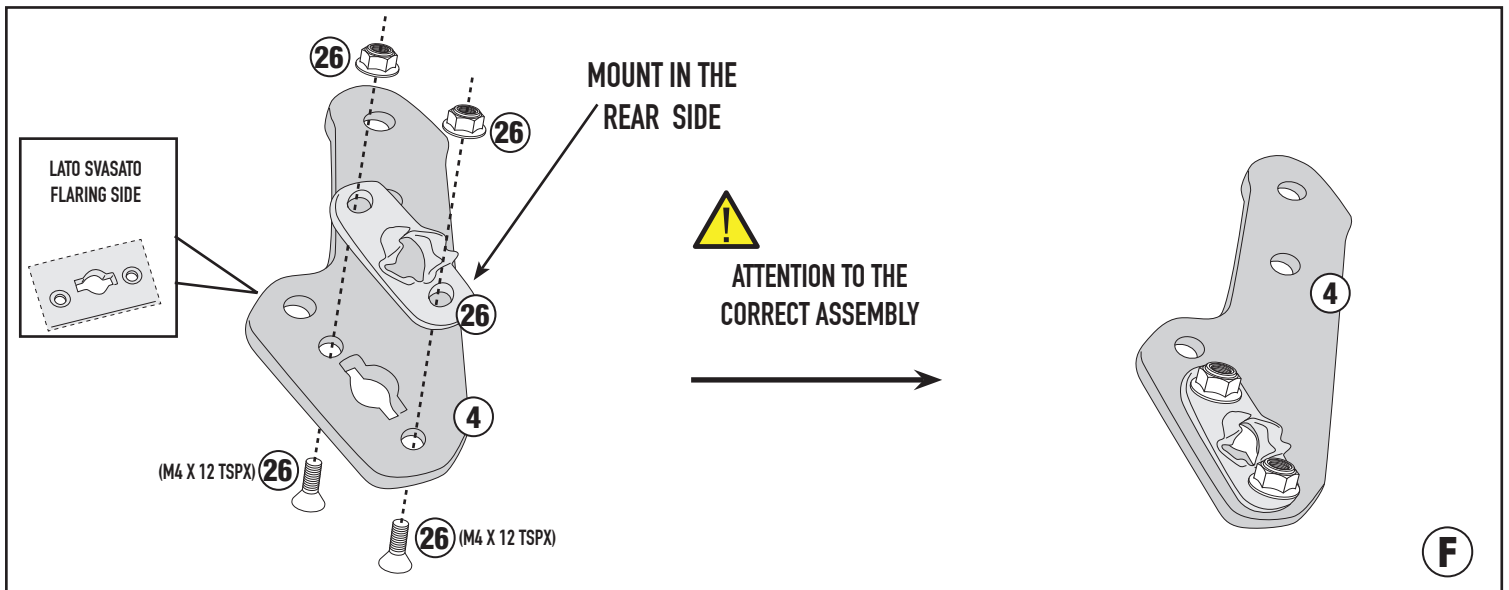
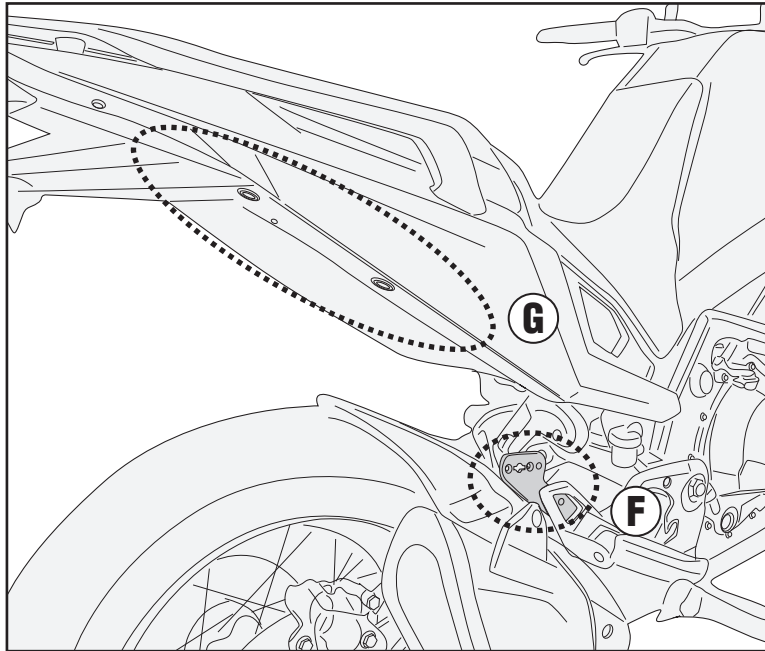

PL09350N - KL09350N

PORTAVALIGIE LATERALE SPECIFICO - SPECIFIC TUBULAR SIDE-CASE HOLDER - PORTE-VALISES LATÉRAUX SPÉCIFIQUE
SPEZIFISCHES STAHLROHR-SEITENTRAEGER - PORTA MALETAS LATERALES ESPECÍFICO - SUPORTE DE MALAS ESPECÍFICO

MOTO MORINI X-CAPE 649 (2021)

ONLY PL09350

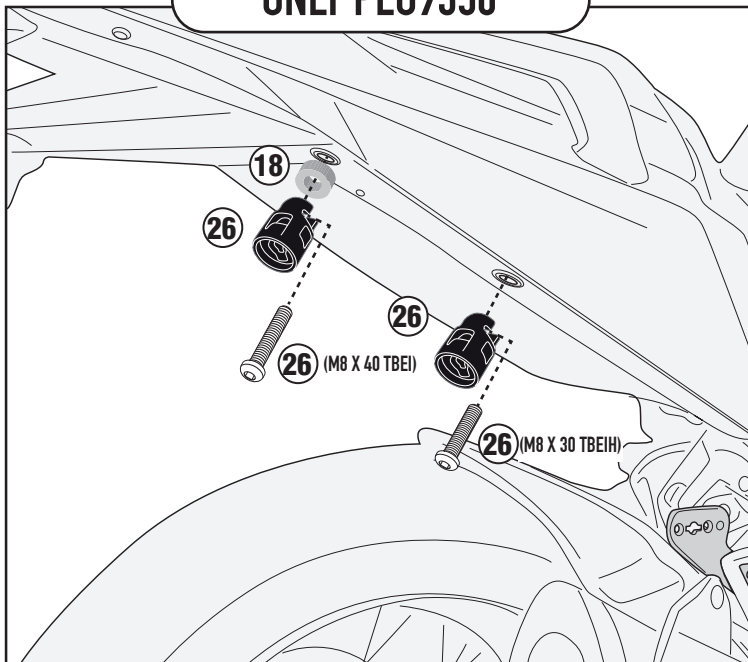

SR9350 + PL09350

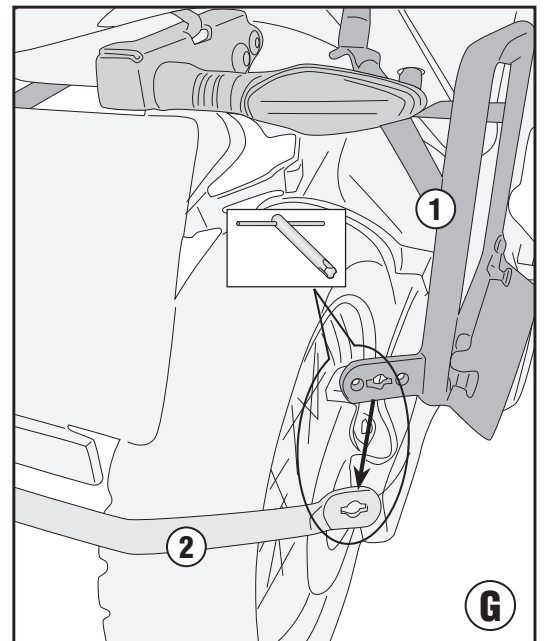
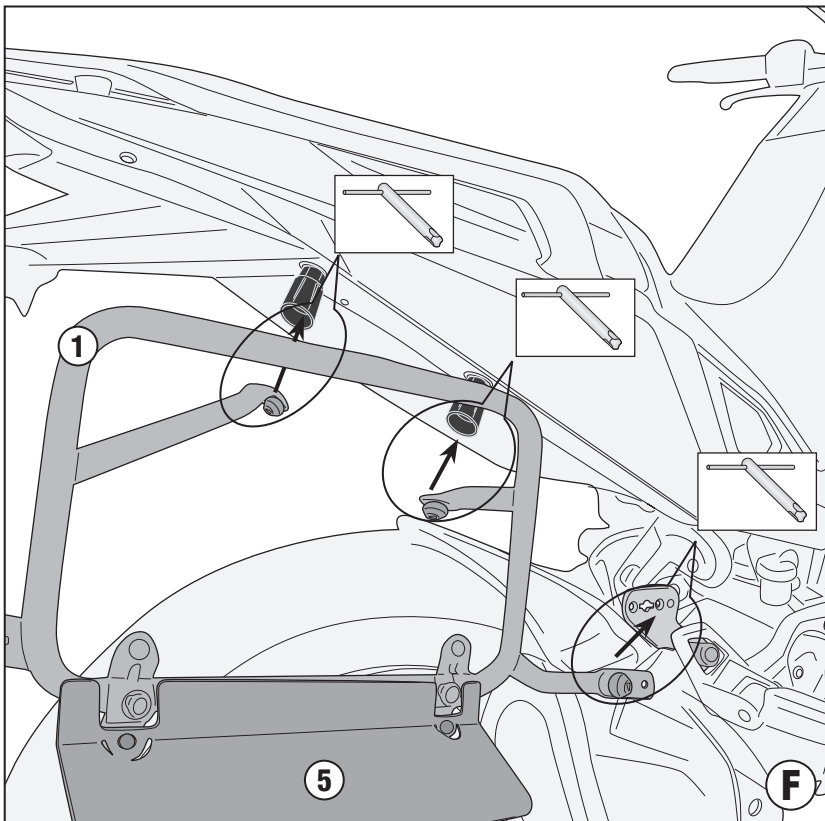
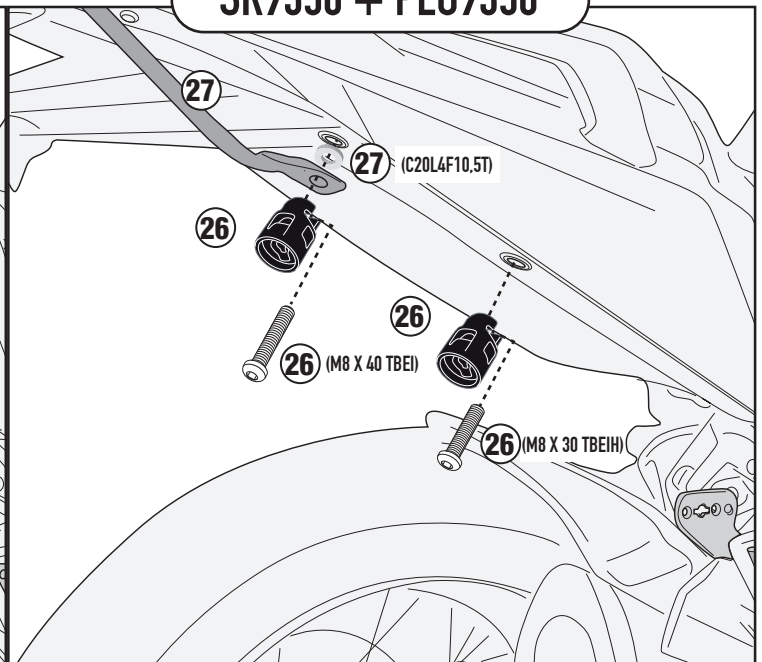

ISTRUZIONI DI MONTAGGIO - MOUNTING INSTRUCTIONS
INSTRUCTIONS DE MONTAGE - BAUANLEITUNG
INSTRUCCIONES DE MONTAJE - INSTRUÇÕES DE MONTAGEM

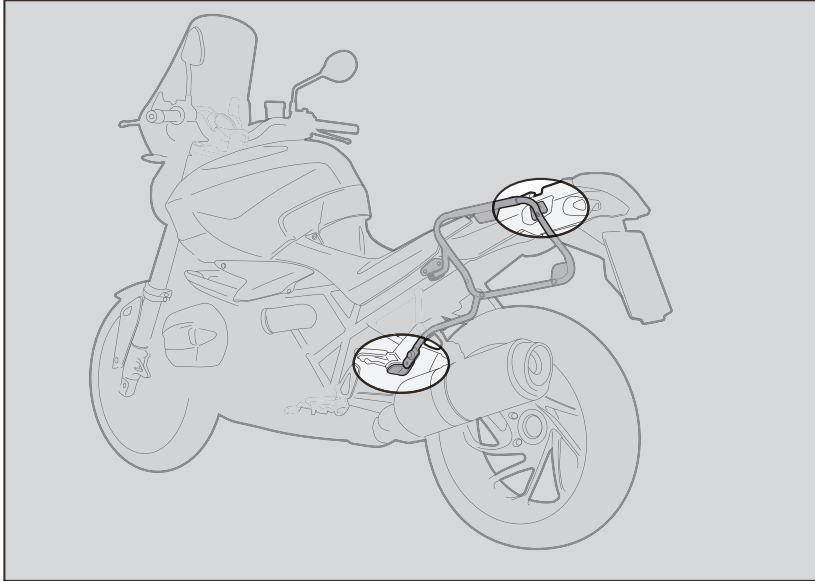

1. INSERIRE L'ATTREZZO NELLA TESTA DELLA VITE SPECIALE;
2. RUOTARE DI 1/4 DI GIRO IN SENSO ORARIO FINO A CHE LA ROTAZIONE NON TERMINA E SI AVVERTE LO SCATTO;
3. PER SMONTARE PROCEDERE IN SENSO INVERSO.

1. INSERT THE SPECIAL KEY INTO THE HEAD OF THE SCREW;
2. TURN THE KEY ¼ TURN CLOCKWISE UNTIL ROTATION STOPS AND THE SIDE CASE HOLDER IS FASTENED SECURELY TO THE FITMENT POINT;
3. IN ORDER TO DISASSEMBLE THE BRACKETRY PERFORM THE OPERATION IN REVERSE.

1. INSERER LA CLE SPECIALE DANS LA TETE DE LA VIS;
2. VISSER D'1/4 DE TOUR DANS LE SENS HORAIRE JUSQU'AU BLOCAGE DE LA VIS POUR MONTER EN TOUTE SECURITE LE SUPPORT A SON POINT DE FIXATION;
3. POUR LE DEMONTAGE, PROCEDER EN SENSE INVERSE.

1. STECKEN SIE DAS WERKZEUG IN DEN KOPF DER SPEZIFISCHEN SCHRAUBE;
2. DREHEN SIE DIE SCHRAUBE 1 / 4 UMDREHUNG IM UHRZEIGERSINN BIS SIE BEMERKEN, DASS DIE SCHRAUBE IM BEFESTIGUNGSPUNKT EINGEKLEMMT IST;
3. FÜR DIE DEMONTAGE FOLGEN SIE DEN HINWEISE UMGEKEHRT.

1. INSERTAR LA LLAVE ESPECIAL EN LA CABEZA DEL TORNILLO
2. DAR ¼ DE VUELTA EN EL SENTIDO HORARIO HASTA QUE LLEGUE AL TOPE Y SE VEA EL TORNILLO;
3. PARA DESMONTARLO PROCEDER EN LA DIRECCIÓN CONTRARIA;

MONTAGGIO - ASSEMBLY - MONTAGE - MONTAGE - MONTAJE

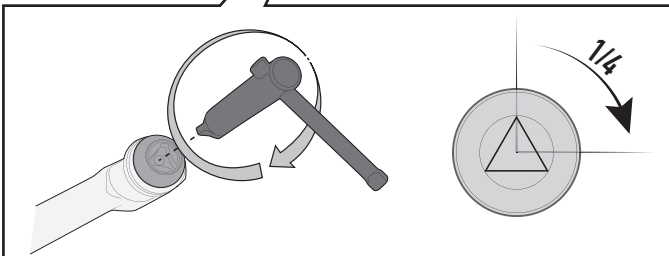
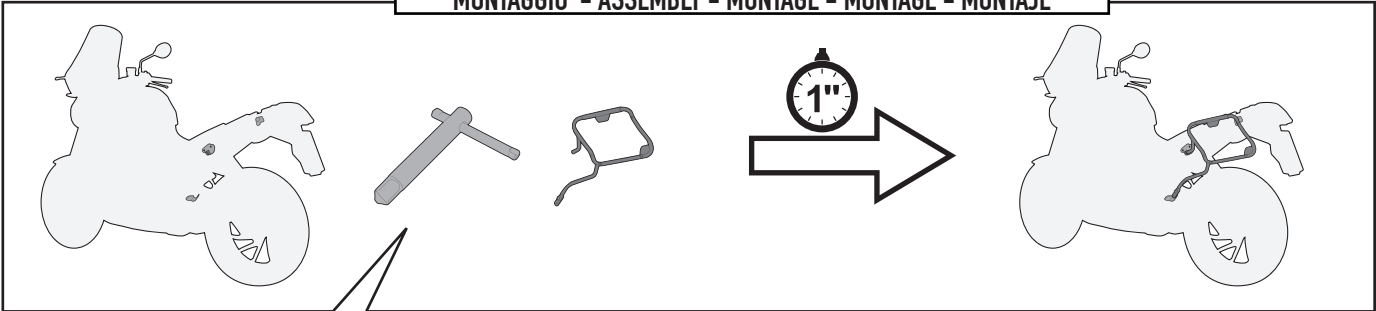

SMONTAGGIO - DISASSEMBLY - DÉMONTAGE - DEMONTAGE - DESMONTAJE

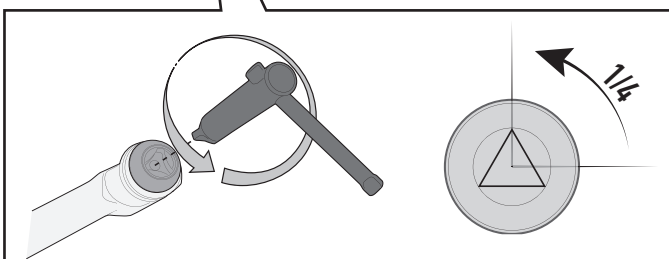
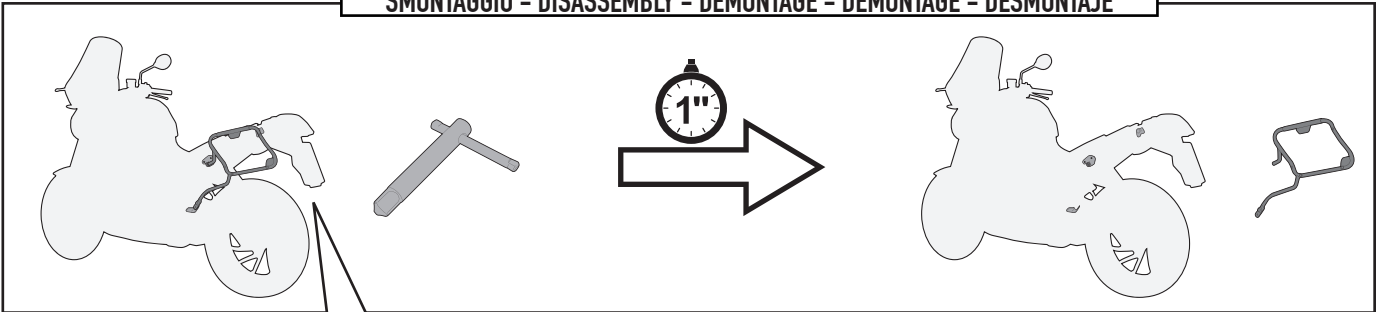

RAPID FITTING

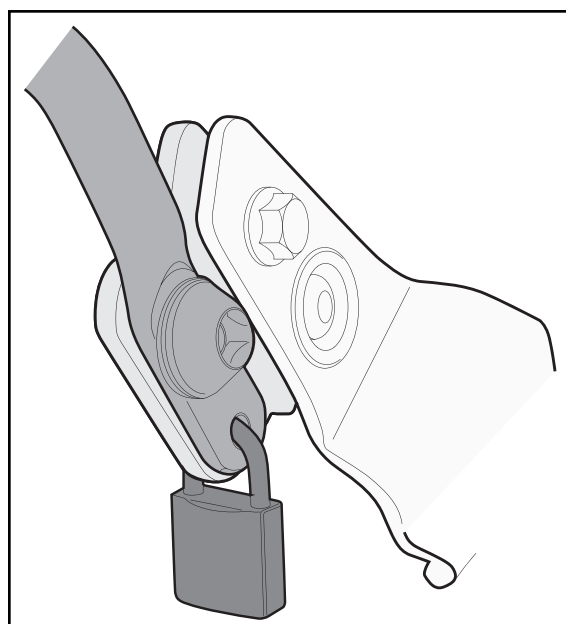
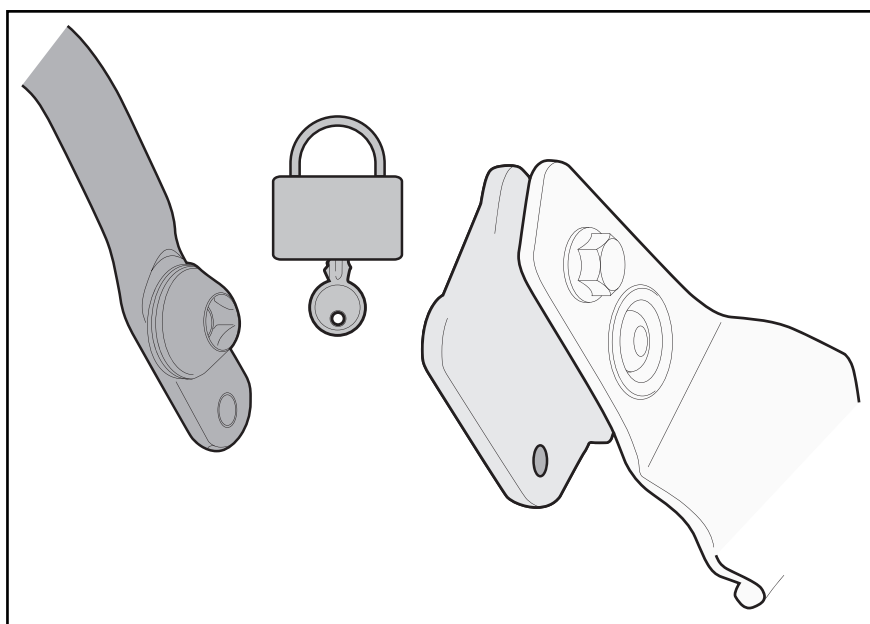
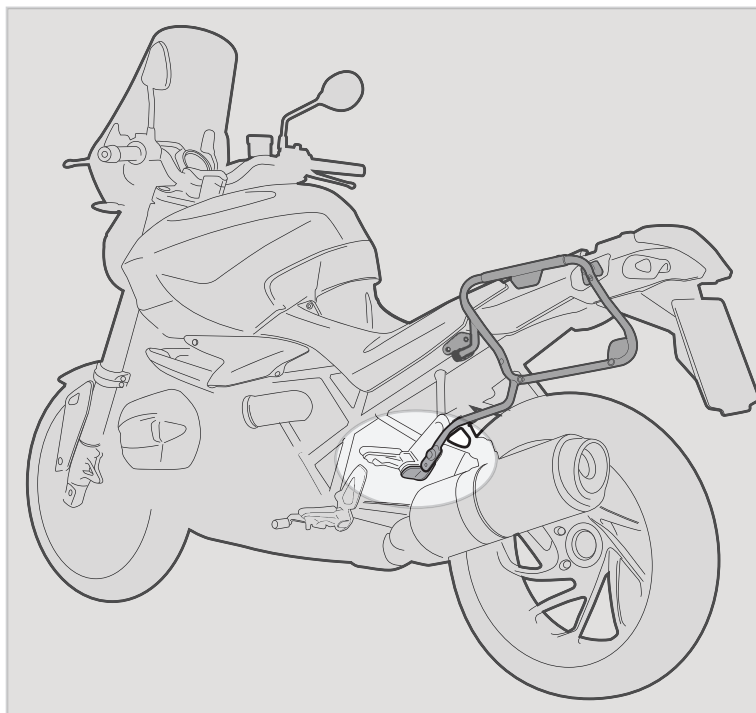

FORO DI SICUREZZA

FORO PREDISPOSTO AD ASSICURARE IL PORTAVALIGIE LATERALE ALLA MOTO (CON UN LUCCHETTO PER ESEMPIO, NON INCLUSO).

SECURITY HOLE

HOLE PLACEMENT IN ORDER TO INCREASE SECURITY OF THE TUBULAR SIDE-CASE HOLDER TO THE MOTORCYCLE (WITH A LOCK, FOR EXAMPLE, NOT INCLUDED).

TROU DE SECURITE

TROU PREDISPOSE POUR ASSURER LE PORTE-VALISE LATERAL A LA MOTO (AVEC UN CADENAS PAR EXEMPLE, NON INCLUS).

SICHERHEITSLÖCH

VORGESEHENES LOCH UM DEN SEITENKOFFER TRÄGER AN DEM FAHRZEUG ZU SICHERN (Z. B. MIT EINEM VORHÄNGESCHLOSS, NICHT ENTHALTEN);

ORIFICIO DE SEGURIDAD

ESTE ORIFICIO ESTA CREADO PARA ASEGURAR EL PORTAEQUIPAJES LATERAL A LA MOTO (POR EJEMPLO CON UN CANDADO, QUE NO ESTÁ INCLUIDO).