

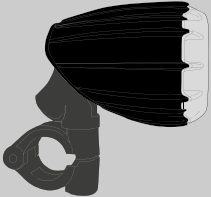





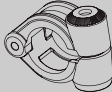

S321

PROIETTORI LED FENDINEBBIA IN ALLUMINIO - LED SUPPLEMENTARY FOG LIGHT PROJECTEURS A LED SUPPLÉMENTAIRES - LED ERGÄNZENDEN NEBELSCHEINWERFER LUZ DE NIEBLA A LED - LUZ DE NEBLINA

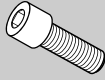
| N° | Descrizione | Caratteristiche | Codice | Quantità | |
|----|--|--|-----------|-----------|---|
| 1 | Proiettore - Floodlight Projecteurs - Nebelscheinwerfer Luz De Niebla - Luz De Neblina | - | - | 2 (Dx,Sx) |  |
| 2 | Interruttore - Cockpit witch Interrupteur - Schalter Interruptor - Mudar | - | - | 1 |  |
| 3 | Fascetta - Clamp Pince - Klemme Abrazadera - Braçadeira | - | - | 2 |  |
| 4 | Fascetta - Clamp Pince - Klemme Abrazadera - Braçadeira | - | - | 1 |  |
| 5 | Riduzione - Reductor Réducteur - Reduktor Reductor - Redução | - | - | 4 |  |
| 6 | Vite - Screw Vis - Schraube Tornillo - Parafuso | TCEI M6x45 | 645TCE | 2 |  |
| 7 | Vite - Screw Vis - Schraube Tornillo - Parafuso | - | - | 2 |  |
| 8 | Copriforo - Bolt Cap Cache Trou - Stopslock Tapa Agujero - Tampa do Orifício | - | Z803 | 2 |  |
| 9 | Coprivite - Screw Cap Cache Vis - Stopsschraube Tapa Tornillo - Bonè a Parafuso | - | Z822 | 2 |  |
| 10 | Dado - Bolt - Ecrou Mutter - Tuerca - Porca | Auto Bloccante Flangiato Ribassato M6 | 6DADIABFN | 2 |  |
| 11 | Cavi - Wire Câble - Kabel Cable - Arame | - | - | 1 | |

S321

PROIETTORI LED FENDINEBBIA IN ALLUMINIO - LED SUPPLEMENTARY FOG LIGHT
PROJECTEURS A LED SUPPLÉMENTAIRES - LED ERGÄNZENDEN NEBELSCHEINWERFER
LUZ DE NIEBLA A LED - LUZ DE NEBLINA

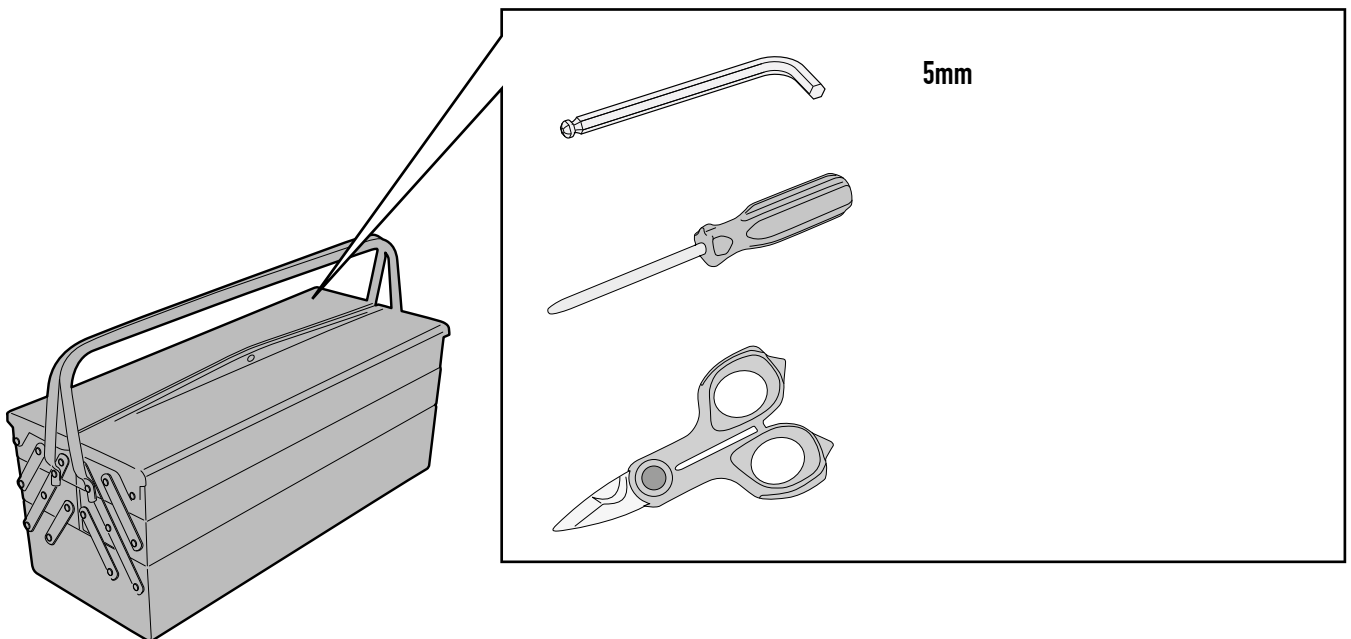
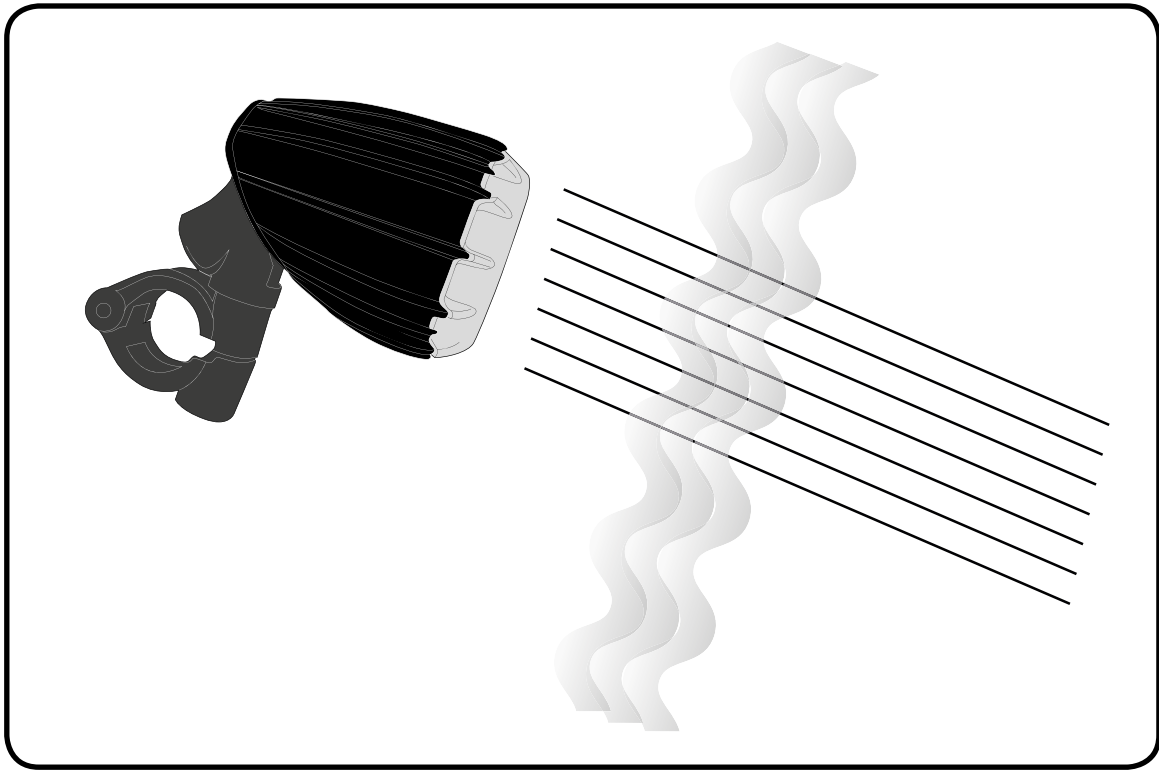

S321

PROIETTORI LED FENDINEBBIA IN ALLUMINIO - LED SUPPLEMENTARY FOG LIGHT
PROJECTEURS A LED SUPPLÉMENTAIRES - LED ERGÄNZENDEN NEBELSCHEINWERFER
LUZ DE NIEBLA A LED - LUZ DE NEBLINA

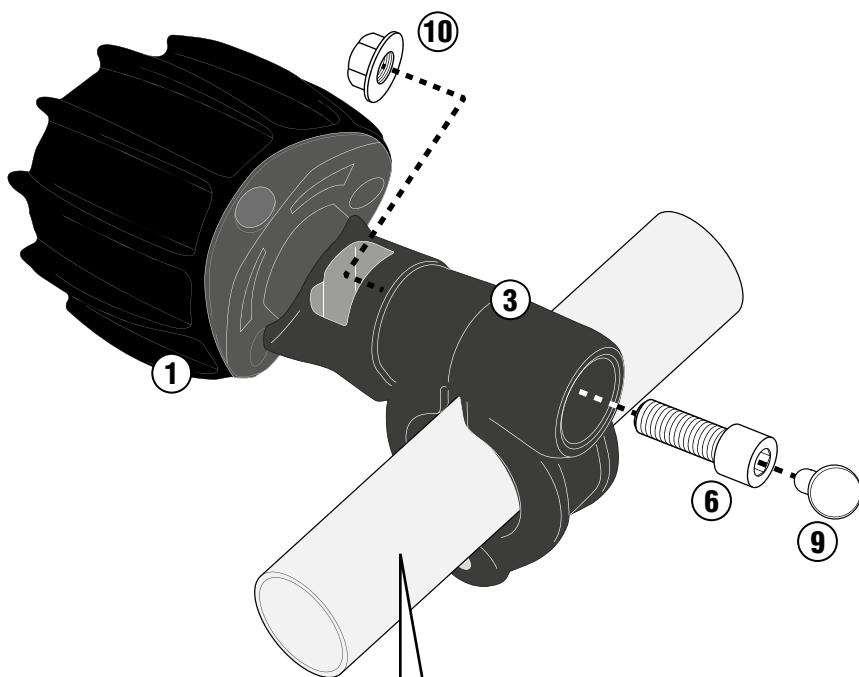
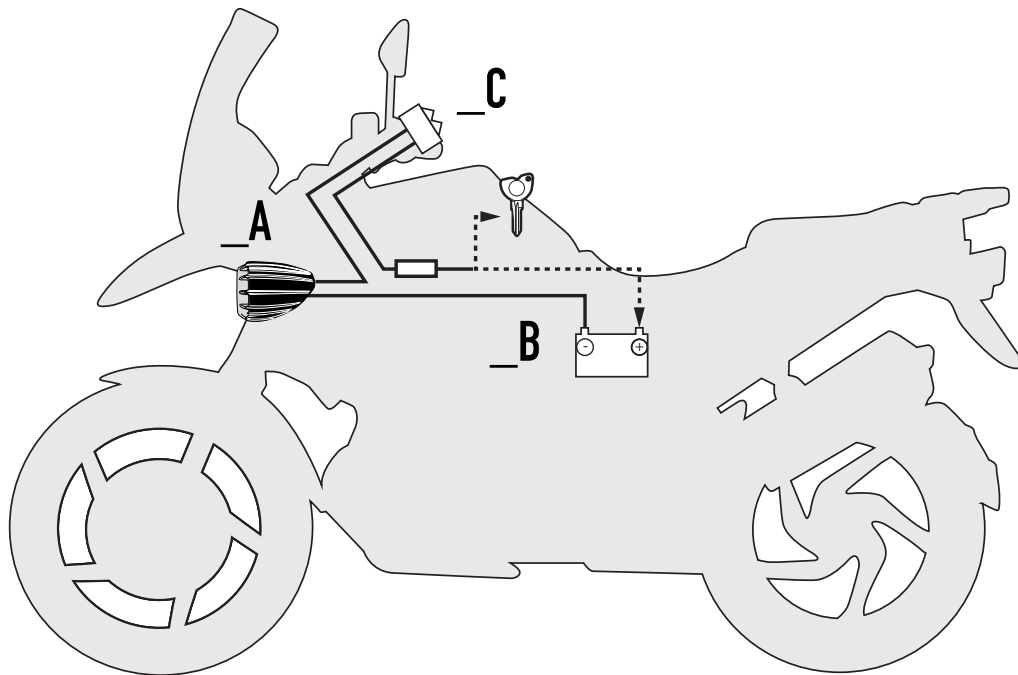

PARAMOTORE
ENGINE GUARD
PARE-CARTER
STURZBÜGEL
DEFENSA DE MOTOR
PARAMOTOR
Ø 21÷25mm

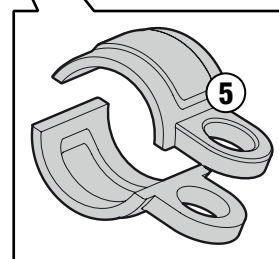
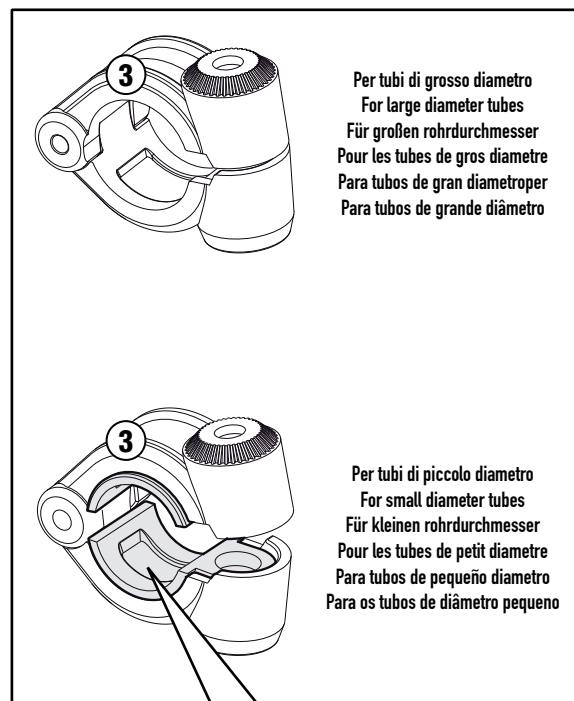

S321

PROIETTORI LED FENDINEBBIA IN ALLUMINIO - LED SUPPLEMENTARY FOG LIGHT
PROJECTEURS A LED SUPPLÉMENTAIRES - LED ERGÄNZENDEN NEBELSCHEINWERFER
LUZ DE NIEBLA A LED - LUZ DE NEBLINA

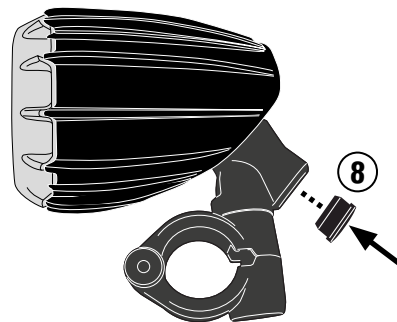
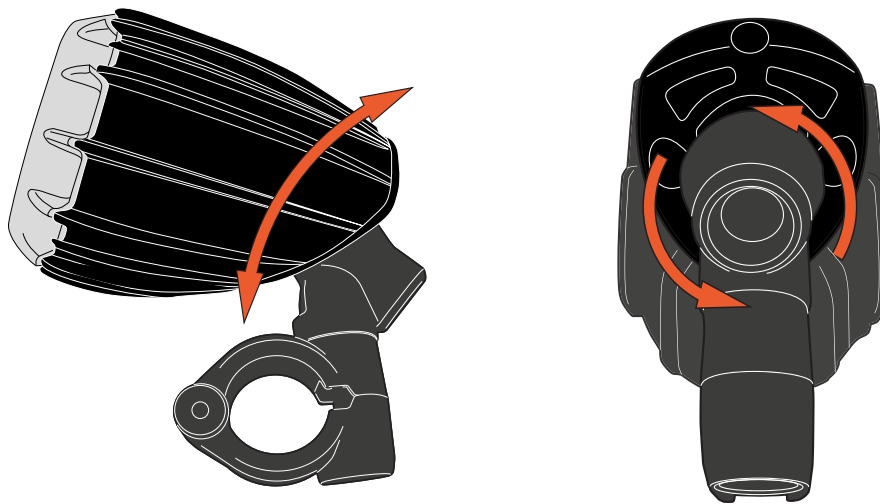
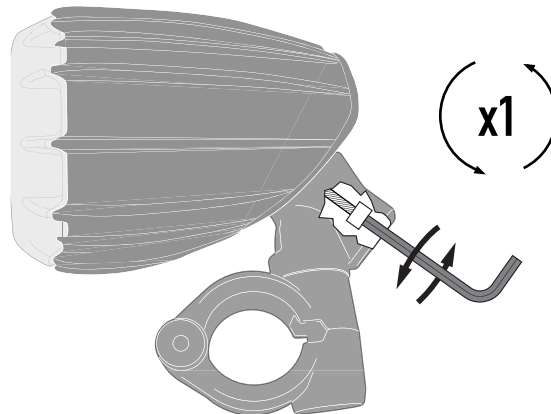

SI RACCOMANDA DI FARE ESEGUIRE IL MONTAGGIO AD UN MECCANICO QUALIFICATO
WE RECOMMEND THAT THE MOUNTING IS CARRIED OUT BY A QUALIFIED MOTORCYCLE MECHANIC
IL EST RECOMMANDE DE FAIRE EXECUTER LE MONTAGE PAR UN MECANICIEN QUALIFIE
WIR EMPFEHLEN, DASS DIE MONTAGE VON EINEM FACHMECHANIKER DURCHGEFÜHRT WIRD
LES RECOMENDAMOS QUE EL MONTAJE SE REALICE POR UN MECÁNICO CALIFICADO
RECOMENDAMOS QUE MONTAGEM É FEITA POR UM MECÂNICO QUALIFICADO

S321

PROIETTORI LED FENDINEBBIA IN ALLUMINIO – LED SUPPLEMENTARY FOG LIGHT PROJECTEURS A LED SUPPLÉMENTAIRES – LED ERGÄNZENDEN NEBELSCHEINWERFER LUZ DE NIEBLA A LED – LUZ DE NEBLINA

ATTENZIONE:

I proiettori S321 sono dotati di lampade LED 8W 12V; per un corretto utilizzo di questo accessorio, nel rispetto delle normative europee, raccomandiamo di porre particolare attenzione al posizionamento dei proiettori sulla moto seguendo le specifiche illustrate in figura _D.

Nel caso in cui i proiettori vengono collegati solamente alla batteria della moto, non si spegneranno automaticamente nel momento in cui si spegnerà la moto, quindi è importante ricordarsi di spegnerli premendo sull'apposito interruttore per evitare di scaricare la batteria. Collegando invece i proiettori al cavo della chiave di accensione della moto (come indicato nella figura _b), nel momento in cui si spegnerà la moto si spegneranno automaticamente anche i proiettori.

N° Omologazione: 0009 E24 04 F3/PL

ATTENTION:

The supplementary fog light S321 are equipped with LED lamps 8W 12V; for a correct use of this accessory, in compliance with European regulations, we recommend to pay particular attention to the positioning of the projectors on the bike according to the specifications shown in figure _D.

In the event that the projectors are connected only to the battery of the bike, they will turn off automatically when you turn off the bike, so it is important to remember to turn them off by pressing on the appropriate circuit breaker to prevent draining the battery. If you connect the floodlight to the ignition key of the bike (as shown in Figure _b), they will automatically stop working when you turn off the bike.

Approval Number: 0009 E24 04 F3/PL

ATTENTION:

Le S320 projecteur sont équipés de LED lampes 8W 12V; pour une utilisation correcte de cet accessoire, en conformité avec la réglementation européenne, nous vous recommandons de porter une attention particulière au positionnement des projecteurs sur le vélo selon les spécifications indiquées dans _D figure.

Dans le cas où les projecteurs sont liés uniquement à la batterie de la moto, ils s'éteignent automatiquement lorsque vous éteignez la moto, il est donc important de se rappeler de les éteindre en appuyant sur le disjoncteur approprié pour éviter de vider la batterie . Si vous connectez le projecteur à la clé d'allumage de la moto (comme le montre la figure _b), ils seront automatiquement s'arrêter de travailler quand vous éteignez la moto.

Numéro d'agrément: 0009 E24 04 F3/PL

ACHTUNG:

Die Nebelscheinwerfer S320 sind mit LED Lampen 8W 12V ausgestattet, für eine korrekte Verwendung dieses Zubehörs in Übereinstimmung mit den europäischen Vorschriften, empfehlen wir ein besonderes Augenmerk auf die Positionierung der Projektoren zu bezahlen auf dem Fahrrad nach den Vorgaben gezeigt Abbildung _D.

Für den Fall, dass die Projektoren nur an die Batterie des Motorrades verbunden sind, werden sie automatisch ausschaltet, wenn Sie das Gerät ausschalten Fahrrad, so ist es wichtig, sich daran zu erinnern, um sie auszuschalten, indem Sie auf den entsprechenden Schalter zu verhindern Entladen der Batterie .

Wenn Sie den Scheinwerfer mit dem Zündschloss des Motorrades (wie in Abbildung _b dargestellt) zu verbinden, werden sie automatisch nicht mehr funktionieren, wenn Sie das Gerät ausschalten Fahrrad.

Zulassungsnummer: 0009 E24 04 F3/PL

S321

PROIETTORI LED FENDINEBBIA IN ALLUMINIO - LED SUPPLEMENTARY FOG LIGHT PROJECTEURS A LED SUPPLÉMENTAIRES - LED ERGÄNZENDEN NEBELSCHEINWERFER LUZ DE NIEBLA A LED - LUZ DE NEBLINA

ATENCIÓN:

El supplementary S321 focos están equipados con lámparas a LED 8V 12W, para una correcta utilización de este accesorio, de conformidad con la normativa europea, se recomienda prestar especial atención a la colocación de los proyectores en la bicicleta de acuerdo a las especificaciones contenidas _D en la figura.

En el caso de que los proyectores están conectados únicamente a la batería de la moto, que se apagará automáticamente cuando se apaga la moto, así que es importante tener en cuenta para apagarlo pulsando en el interruptor adecuado para evitar que se agote la batería . Si conecta el proyector a la llave de encendido de la moto (como se muestra en la Figura _b), automáticamente dejará de funcionar cuando se apaga la moto.

Número de autorización: 0009 E24 04 F3/PL

ATENÇÃO

Os faróis suplementares S321 estão equipados com lâmpadas LED 8V 12W, para o uso adequado deste acessório, de acordo com as normas europeias, recomenda-se atenção especial para a colocação dos projetores na moto de acordo com as especificações da figura _D.

No caso em que os projetores estão ligados apenas à bateria da moto, ele vai desligar automaticamente quando você desliga a moto, por isso é importante lembrar-se de desligá-lo pressionando o botão apropriado para evitar a descarga da bateria. Se você conectar o projetor para a ignição da moto (como mostrado na Figura _b) irá parar de funcionar automaticamente quando você desliga a moto.

Número de aprovação: 0009 E24 04 F3/PL

